

Seacliff Improvement Association



Please join us for a special Holiday Clean up in Seacliff Village!



Saturday December 15th 9:00am-10:00am



Meet in the parking lot in front of the Forget Me Not and Mad Molecule shops. Bring your Trash Bags and your Holiday Cheer. Santa Hats and Antlers are welcome!

The Seacliff Improvement Association cordially invites you to perform *Senseless Acts of Beauty* in Seacliff. At our cleanup last month we prepared the beautiful wooded area directly above Seacliff Village for a sign overhaul. The Sign is almost complete and we need volunteers to help clean and prune around the area where we will plant new ground cover. We will also clean up several lots in the area and our lovely Seacliff Triangle.

We get together monthly to spruce up Seacliff Village in a collaborative effort with State Parks, Seacliff Improvement Association, Seacliff Village merchants and residents. Come and bring your pickers, pruners, shears, weed whackers, and garden gloves- we will provide bags, water and haul away. And remember, it only last for one hour so join us to see how much we can accomplish in 60 minutes!

Together we can make a difference!

Help make Seacliff the beautiful place we love to call home. Please send your RSVP to: info@seacliffimprovement.org as soon as possible, so that we will know how many will attend. We look forward to seeing you there.

Time to Renew Your Dues!

\$20 is such a deal and supports all the good works in our community.

Send your check to:

Seacliff Improvement Association, PO Box 533, Aptos, CA 95001

Final Public Meeting Held for the Streetscape Design

Will Roblin

Seacliff residents received an update on the Utility Undergrounding and Streetscape Improvement projects at a recent county-sponsored community meeting. County Public Works Senior Engineer Jack Sorhiakoff reported that a section of path was successfully redesigned and PG&E is now clear to trench down Coates Drive. Even more satisfying, the project cost has not changed. While these arrangements clear the path for utility undergrounding throughout the village, actual construction is still several weeks away and will last several months.

Jack also reported progress on the long awaited streetscape improvements. Once undergrounding is complete, surface level work can begin, thanks to cooperative design efforts by the department of Public Works and State Parks. For the two small state owned parcels at the southeast end of State Park Drive, State Parks' landscape architects provided designs that the County could accept and build. While State Parks retains title to the Seacliff Beach State Park entry, the design integrates the Park entry with the village's public plaza. Title transfer for these two lots is currently being determined.

An important part of maintaining the landscaping, once it is established, is paying for the water to keep the plants healthy. Mr. Sorhiakoff said Seacliff residents and businesses will need to pay for the water to maintain the landscaping. Our association will work with local businesses to determine a way to share the cost for maintaining the plants after they are established.

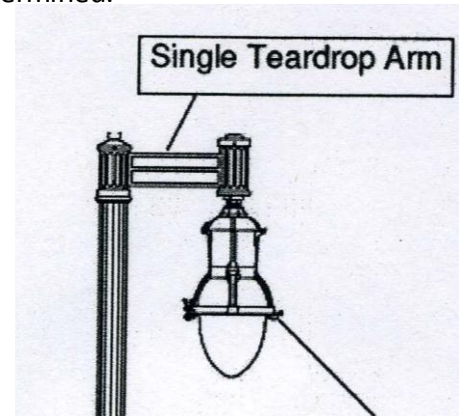

Meeting participants chose the single teardrop lighting style (see illustration) and wholeheartedly supported retaining the tree-lined median along Center Avenue included in the design. There was a suggestion that low shrubs replace the trees to accommodate the mobile homes that are currently routed through the village. This idea was rejected by residents who feel our small village neighborhood should not have to sacrifice its improvements for wide loads travelling to other parts of the county. Since groundbreaking will not happen for months, this should give movers plenty of time to find another route.

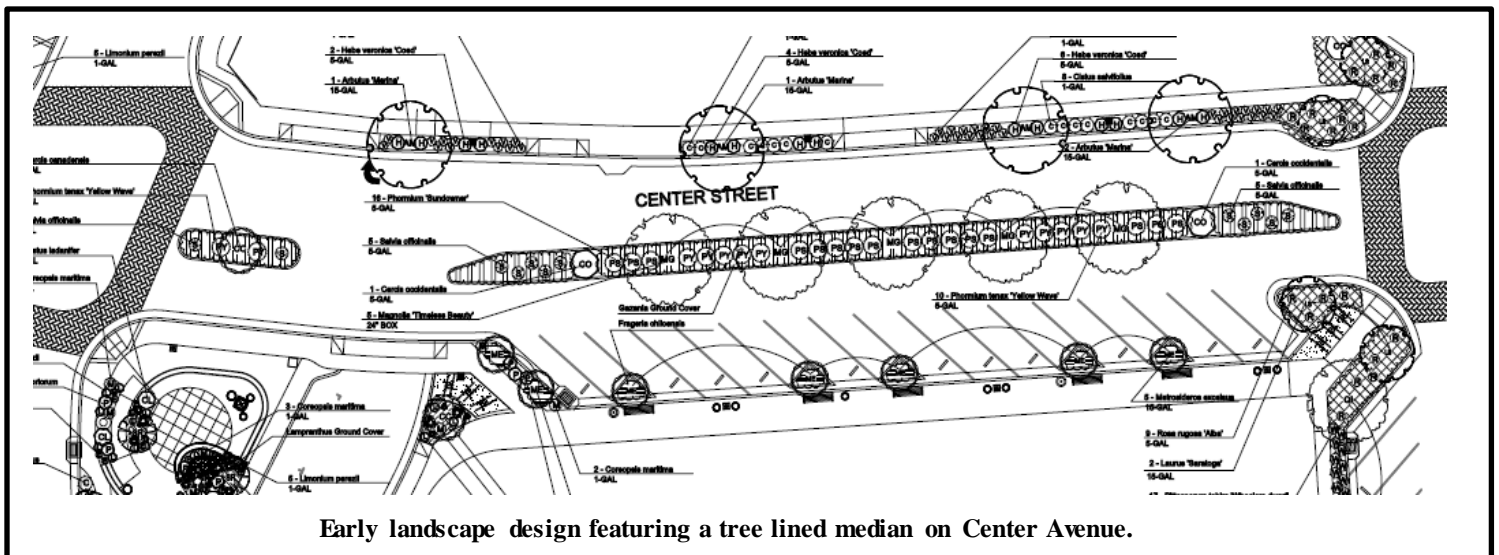

Early landscape design featuring a tree lined median on Center Avenue.

Neighborhood Park to Break Ground in 2014

Kate Minott, SC County Parks Commissioner

A couple dozen Seacliff residents braved the evening chill on November to hear representatives from the Santa Cruz County Department of Public Works describe the progress of the highly anticipated neighborhood park in Seacliff. SSA Landscape Architects, Inc. has been completing the existing plans for the park and will take the project through the environmental protection and development permit phase. If all goes well, there could be a ribbon cutting for the new park in 2014.

Representing SSA Landscape Architects, Scott Reeves briefly reviewed the McGregor Neighborhood Park

Master Plan, estimating a hefty \$1.4-million dollars will be needed to build the envisioned McGregor Park in its entirety. Mr. Reeves explained the economic issues and other factors supporting the firm's proposal that the park be constructed in two phases. After Mr. Reeves unveiled a conceptual drawing of the park's first phase, Assistant Public Works Director, Betsey Lynberg noted it was Supervisor Ellen Pirie's unflagging advocacy for the neighborhood park that persuaded the SC County Board of Supervisors to approve \$650,000 toward construction of the park's first phase.

Most of Phase One focuses on the northern section of the 1.25-acre park. Drawing guidance from the Master Plan, Mr. Reeves described the park design

as dotted with drought-tolerant trees and shrubs with a small mowed area where the future 'skateable art' pieces will someday be installed. Phase One includes a fenced tot lot with benches and two sheltered picnic tables nearby. Sewer and utility lines will be stubbed in for the future bathroom, but until then, a portable restroom will be maintained by Parks Staff. Seacliff neighbors suggested reprioritizing some park elements

including a new sidewalk along the East parameter of the park for pedestrian safety next to McGregor Road. Other priorities attendees identified included the need for security lighting to discourage loitering in the park after hours, a hand wash station near the portable restroom and a well-stocked doggie-bag station. Although the park is

currently referred to as McGregor, the county still seeks an official name. What do you think it should be called? The county wants to hear from you!

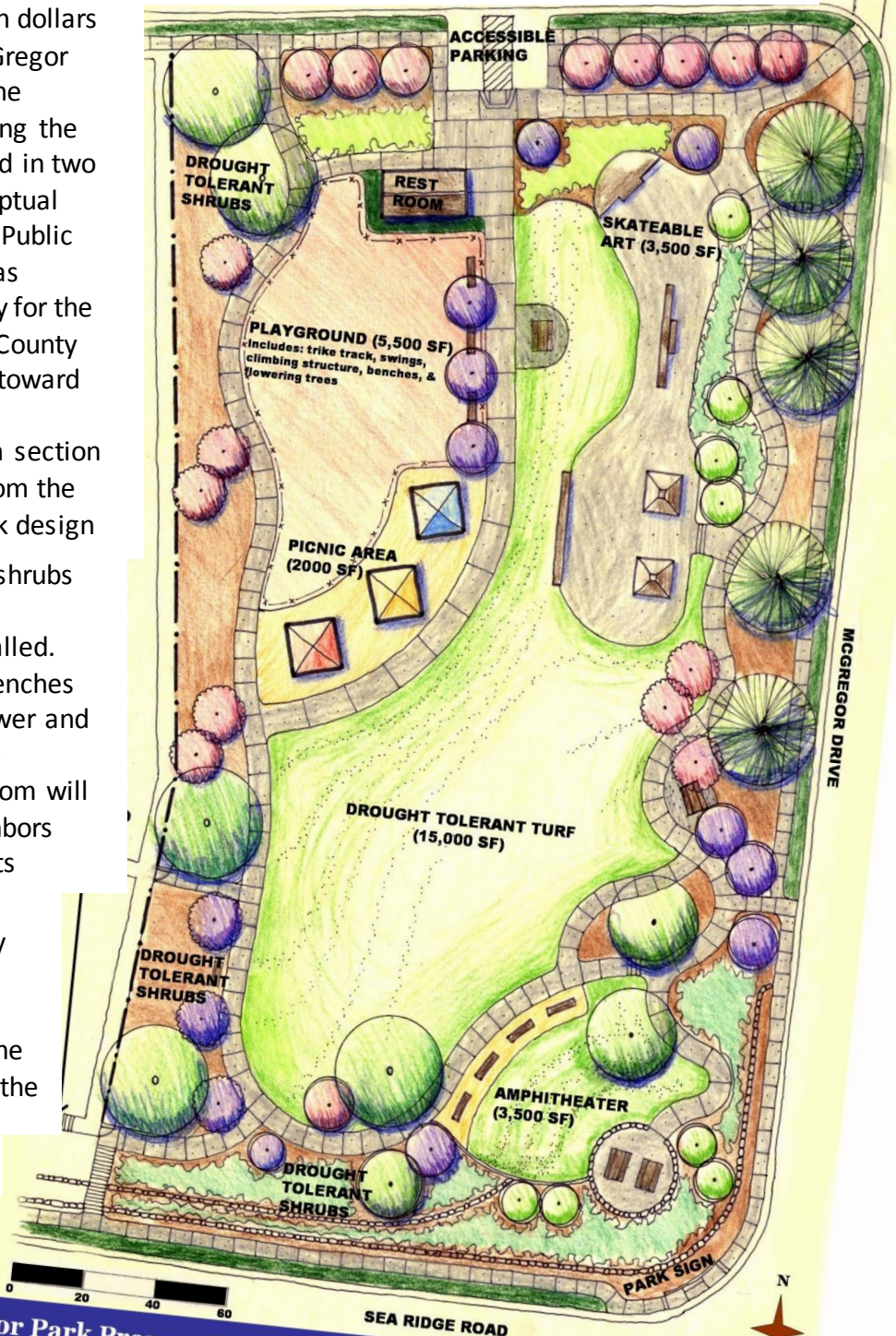

McGregor Park Proposed Draft Master Plan
October 6, 2008 Parks and Recreation Commission Meeting



Proposed Scenic Rail Trail Runs Through Seacliff

Rebecca Downing



Upon completion of the rail line purchase from Union Pacific Rail Road, the Santa Cruz Regional Transportation District (RTC) held a Whistle Stop celebration and a series of public meetings to present the master draft plan for the scenic rail trail project. Because the scope of the plan is very large, twenty segments were created to more easily organize the route to prioritize construction. Segments are defined as potential trail projects with logical beginning and end points with the intent that each segment will be funded, designed, and constructed as a whole.

Segments 11 and 12 run through Seacliff with Segment 11 ending at State Park Drive where Segment 12 begins. As the trail heads south through Seacliff, the trail route will be located on the ocean side of the railroad tracks. This presents some challenges since portions of the corridor through this area are very narrow. The plan states:

The rail corridor along the length of Poplar Street to Mar Vista Drive is just 34 feet wide. The trail would be forced between a narrow landscape buffer between Poplar Street and the railroad corridor. The trail alignment would continue down the coast side of the tracks after crossing the Mar Vista Drive intersection using the existing crosswalks. Crosswalks and possibly the intersection corners would need to be modified to provide a safe crossing for bicycles and pedestrians.

If you walk or cycle through this area, you might have some suggestions for the RTC as they revise the plan. You can read the plan online at: <http://sccrtc.org/projects/multi-modal/monterey-bay-sanctuary-scenic-trail/mbsst-master-plan/>. Written comments on the document will be received until December 21, 2012 at info@sccrtc.org.



Locals enjoyed the liquid sunshine as they celebrated the RTC purchase of the rail line.

Come to the Corridor Study Session

Will Roblin

The County's extensive study of possible paths to walkable communities, with plans to locate housing and jobs together to promote village creation and the specifics of sustainability in Santa Cruz County continues on its multi-year path. Public workshops in October drew out community visions of sustainability. The next step is for the advisory group and public to attend a Planning Commission public meeting December 12th for a "study session." Land use focus areas will be discussed in light of alternative land uses, densities, circulation options and site design choices. Seacliff residents are encouraged to attend:

Santa County Planning Commission/TCP Advisory Group Study Session
Wednesday December 12th 6:30 pm 5th Floor 701 Ocean St, Santa Cruz

Identifying underutilized sites, reviewing land use policies, accounting for traffic realities and attempting to implement a vision for the future are the sometimes contradictory efforts of this study group. For more information visit: www.transitcorridorsplan.org

Lots to Celebrate at our Annual Dinner!

The annual Seacliff Improvement Association event held at the Seascape Golf Course was, as always, a big success. It was a great time to catch up on the latest Seacliff news and to thank our members for supporting the work of the association. Local businesses and SIA members contributed some fabulous door prizes and, thanks to the new TV screens at Seascape Golf Course, we could keep up with the San Francisco Giants game as we enjoyed our buffet.

Let's do this again next year!



Debbie is ready to win!



Beautiful Decorations by Deb and Margaret



Ken Constable serenades the Diners



Even the Centerpiece was a prize!



Time to Celebrate!

Have You Been to The Med Lately?

The Mediterranean has been around for over forty years but was not the local pub many residents chose to patronize. That is, until Bob Tapella bought The Med and gave it a wonderful makeover!

Bob has invested over \$40,000 refurbishing and deodorizing the inside to remove years and layers enjoyed by the previous clientele. The Med's selection of beverages has changed too and now offers more premium choices and a variety of boutique brews. For patrons who like to play while quaffing a tall one, Bob also put in a pool table, a dart board and a pinball machine. Bob has also installed 5 TVs – he *loves* sports! For music, there is a new jukebox with a selection that is sure to please the locals. There have been some staffing changes and the Med now opens at 8 am instead of 6! He even hired a janitor to sweep outside to keep the area clean and inviting. Are you getting thirsty?



Thank You Beachgate Neighbors!

Seacliff residents love a good beach walk so getting down to the beach for that walk became a lot safer thanks to the neighbors who love the Beachgate stairs. The 40-50 years old stairs were in desperate need of repair but there was no State Park budget for materials so the neighbors took up a collection and raised \$2,550! State Parks Maintenance Supervisor Jeff Long was able to put his crew to work in September to complete the repairs before winter. Many thanks go to Jeff Long and his crew, Steve and Dianne Pereira, Ben Strock, David and Norma Baer, Bernard Gregoris and Martha Johnson, Ken and Andrea Miller, John and Becky Glikbarg, Kate Minott, Don English, Dick and Heidi Garwood, David Ralston, and the Turner and Brewer families. (Photos taken by Will Roblin on a sunset walk with his wife Cher and their dog, Danny.)



Save the Date! May 11, 2013 34th Annual Human Race



HUMAN RACE



Deb Murray

Santa Cruz County's 34th Annual Human Race Walkathon and Fun Run will take place on May 11, 2013. The Human Race is a nationwide community fundraising event where our community comes together for a good cause. The Human Race is the SIA's primary fundraiser. The money we raise will be used for activities and expenses including improving the many Seacliff gardens we maintain.

Our 2013 goal is to raise \$2,700 or more!

To reach this goal we will need your help. We encourage all of you to participate and walk with us. It's really a fun day with a beautiful walk along West Cliff Drive in Santa Cruz. At the conclusion there will be a BBQ lunch with entertainment too!

More details in the New Year...

Seacliff Improvement Association
 TREASURER'S REPORT FOR 2012
 January 1, 2012 thru November 30, 2012

BEGINNING CASH BALANCE (1/1/2012)	\$20,229.74
INCOME:	
Donations	260.00
Membership	4,914.99
Human Race - Net	2,000.15
Other Income	186.67
TOTAL INCOME	7,361.81
EXPENSES:	
Web Host and Domain	107.40
Newsletter Publishing	1,700.26
Postage	166.50
Mini-Park Maintenance	266.38
Park Strip Maintenance	382.12
Insurance Expense	569.00
Annual Dinner	516.73
Beautification Awards	200.00
Other Expenses	626.54
TOTAL EXPENSES	4,534.93
ENDING CASH BALANCE	\$23,056.62

Welcome New Members!

Thomas and Susan Barbour
 Frank Baudino
 John and Carol Cook
 Alice Flynn
 Dennis A. Garite
 Paula Hucal and Brian
 O'Halloran
 Fred Pollack
 Stacey and Craig Ristow
 Charles and Esther Wilson

***We thank all 316 members
 for your continued support!***

Visit: <http://www.seacliffimprovement.org/>

Write to us at: info@seacliffimprovement.org

Community Contacts

Sheriff's Sub-Station Rancho Del Mar Center	Sergeant Paul Ramos	662-0690
Abandoned Vehicle Abatement Desk	(need location, color, make, model & license plate)	454-3139
California Highway Patrol	24 Hour Non-emergency - for cars blocking the road	796-2160
Aptos/LaSelva Fire District	Fire Chief, Jeff Terpstra	685-6690
Santa Cruz County Offices	2nd District Supervisor, Ellen Pirie	454-2200
	Sector Superintendent, Pajaro Coast Sector, Kirk Lingenfelter	429-2881
California State Parks	Seacliff Supervising Ranger, Kevin Best (Dogs off-leash, dead animals, etc.)	685-6442
	Seacliff Park Maintenance Supervisor, Jeffrey Long	475-0164
Aptos Chamber of Commerce	Executive Directors: John and Karen Hibble	688-1467
Graffiti Abatement Project	Larah Connell	427-0462

**Seacliff Improvement Association
PO Box 533
Aptos, CA 95001-0533**

Seacliff Improvement Association

Membership Application/Renewal
Annual Dues are \$20.00 (January—December)



Name(s): _____

Seacliff Address: _____ State: _____ Zip: _____

Mailing Address if different: _____ State: _____ Zip: _____

Telephone Number: (_____) _____

E-mail Address (for SIA alerts & notification): _____

Please send my Quarterly Newsletter by E-mail: (check here)

The SIA does not give out membership lists or phone numbers except to a fellow member for valid membership purposes. If this policy does not provide sufficient privacy, please check either of the two choices following:

- Consult me before giving out my address or phone number to any SIA member
- Do not give out my address or phone number to any SIA member

Please sign me up to volunteer for:

- Annual Fundraiser
- Maintaining Gardens
- Community Emergency Response Team
- Beautification Committee

=====✂=====✂=====✂=====✂=====

Please include your check and mail to: Seacliff Improvement Association, P.O. Box 533, Aptos, CA 95001